



*Great sound  
from Barcelona  
since 1972*

[www.amateaudio.com](http://www.amateaudio.com)

## User's manual

# S26P/8      S26P/16

# NÍTiD

*#purelynitid*

April 2024

Amate Audio S.L.

EXPORT & CUSTOMER SERVICE  
Perpinyà, 25 · Polígon Industrial Nord  
08226 Terrassa · Barcelona – SPAIN  
T. +34 93 735 65 65  
[export@amateaudio.com](mailto:export@amateaudio.com)

R&D, FACTORY AND MANAGEMENT  
Violinista Vellsolà, 18  
08222 Terrassa · Barcelona – SPAIN  
T. +34 93 736 23 90  
[info@amateaudio.com](mailto:info@amateaudio.com)

---

## Safety Instructions

1. All safety instructions must be read before using this device.
2. Keep and follow these instructions
3. Heed all warnings
4. The exclamation mark in the triangle indicates internal components which if replaced can affect safety.
5. The lightning symbol within the triangle indicates the presence of dangerous uninsulated voltages.
6. Only clean the device with a dry cloth.
7. Do not block any ventilation openings. Install in accordance with the manufacturer's instructions.
8. Do not install the device near heat sources such as radiators, heaters or other heat-emitting elements.
9. Protect the power cord from being walked on or pinched, particularly at plugs, convenience receptacles, and the point where they exit from the apparatus
10. The equipment must be repaired by qualified technical service personnel when:
  - A. The mains supply cable is damaged, or
  - B. Any object or liquid has damaged the device; or
  - C. The equipment does not function normally or correctly; or
  - D. The equipment has been exposed to the rain; or
  - E. The chassis is damaged
11. Disconnect the device in the case of electric storms or during long periods of disuse.
12. **WARNING** – To reduce the risk of fire or electric shock, do not expose this device to rain or moisture
13. The equipment shall not be exposed to dripping or splashing and no objects filled with liquids, such as vases, shall be placed on the device.
14. For hanging and installation, use manufacturer recommended accessories only.

## 1. INTRODUCTION

### 1.1. General

Amate Audio would like to thank you for your confidence in our NÍTID Series. We suggest you to carefully read the following instructions in order to obtain the best results in performance.

### 1.2. Features and presentation

#### S26P

- Passive acoustic system
- NL4MP Speakon input & parallel output
- 400 W program power
- Sensitivity 1 W / 1 m: 95 dB
- 2 x 6" neodymium magnet woofers with 1.5" voice coil and fibre cone
- 1" PEN diaphragm neodymium magnet compression driver
- 70° (H) x 70° (V) dispersion horn
- 8Ω and 16Ω available

## 2. CONNECTIONS

### 2.1. Connection description

**A) SPEAKON:** The S26P uses two NL4MP Speakon terminals and are duly prepared for a perfect connection in a parallel system. Terminal Pins +1/-1 must be always used, disregarding the +2/-2, which are not internally connected. Respect always the polarity +/-.

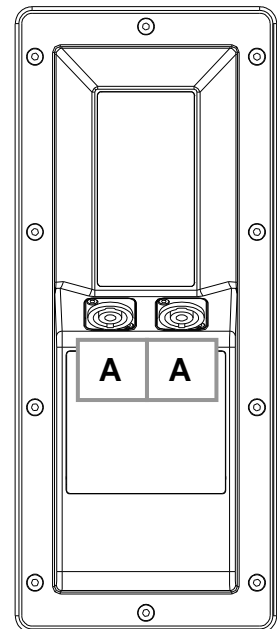

Fig. 1. NÍTID passive connectors



It is strongly recommended to use a two-conductor high quality wire, non-shielded and two-coloured. We recommend using a minimum section of 4 mm<sup>2</sup> for each conductor. Avoid long wire distances as they induce to important power and quality losses.

### 2.2. Configurations

#### 2.2.1. Full-range stereo configuration

Connect each output of the amplifier LEFT/RIGHT to each cabinet using two independent wires.

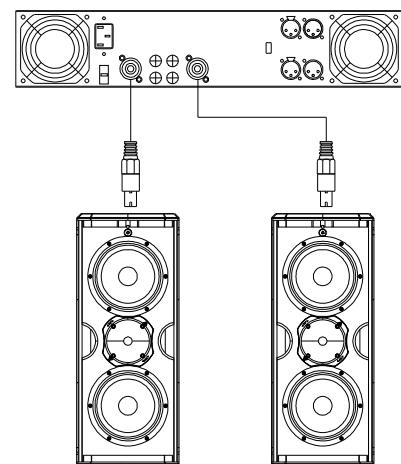
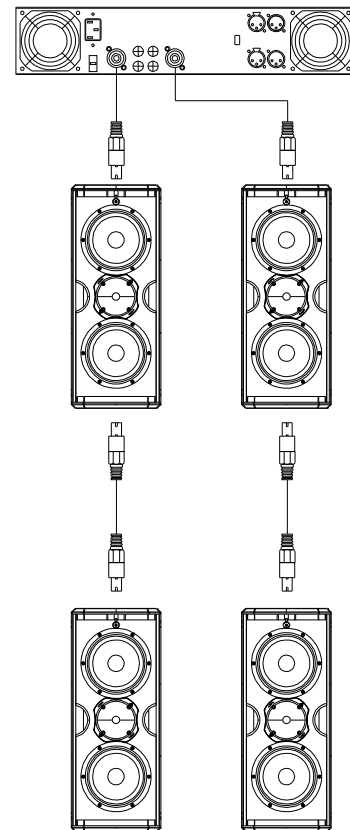

Fig. 2. Full-range stereo configuration

**2.2.2. Full-Range parallel stereo configuration**

Connect the amplifier's output to the Speakon's input of the first cabinet, always respecting the polarity positive +1, negative -1. Then, make a bridge from the first cabinet to the second one.



**Fig. 3.** Full-range parallel stereo configuration

**2.2.3. Passive configuration with subwoofer**

There will be times when you will be interested in reinforcing your NITID Systems with subwoofer units, in passive mode. In this case, only one amplifier will be used for the whole system.

Connect one of the outputs of the amplifier to the subwoofer through a wire. Then, make a bridge from the link Speakon connector of the subwoofer to its respective mid-high top unit, always respecting the correct polarity between both systems. Do the same with the other channel.

It is also correct, if the installation requires so, to make the connection in the opposite way, that is, from the amplifier to the top cabinet and then to the subwoofer.

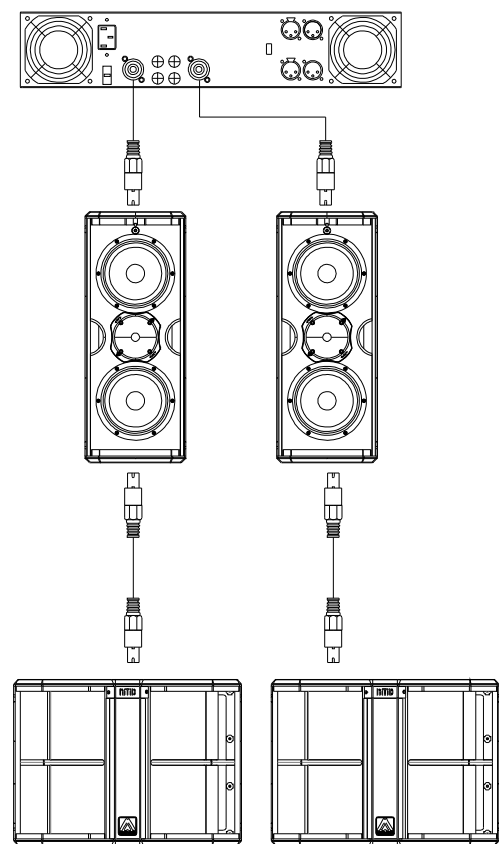

**Fig. 4.** Passive configuration with subwoofer

**2.2.4. Bi-Amplified configuration with subwoofer**

A wire with the maximum available section (4mm<sup>2</sup> minimum) should link the low frequencies output channel of the amplifier to one of the subwoofers. Two subwoofers can be also connected by bridge one to another, as long as the polarity is strictly respected.

Connect the other output of the amplifier to the Full-Range cabinets.

It is also possible to use only one amplifier for the low reinforcement, connecting each one of the subwoofers to the two outputs of the amplifier and consequently, connecting the Full Range cabinets to a second amplifier.

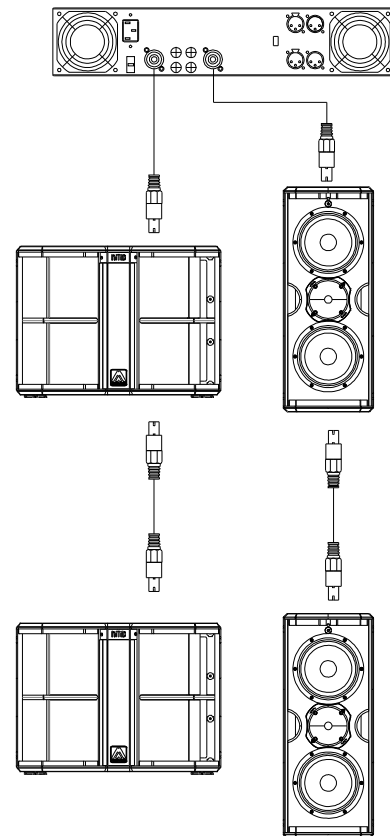

**Fig. 5.** Bi-amplified with subwoofer configuration (option 1)

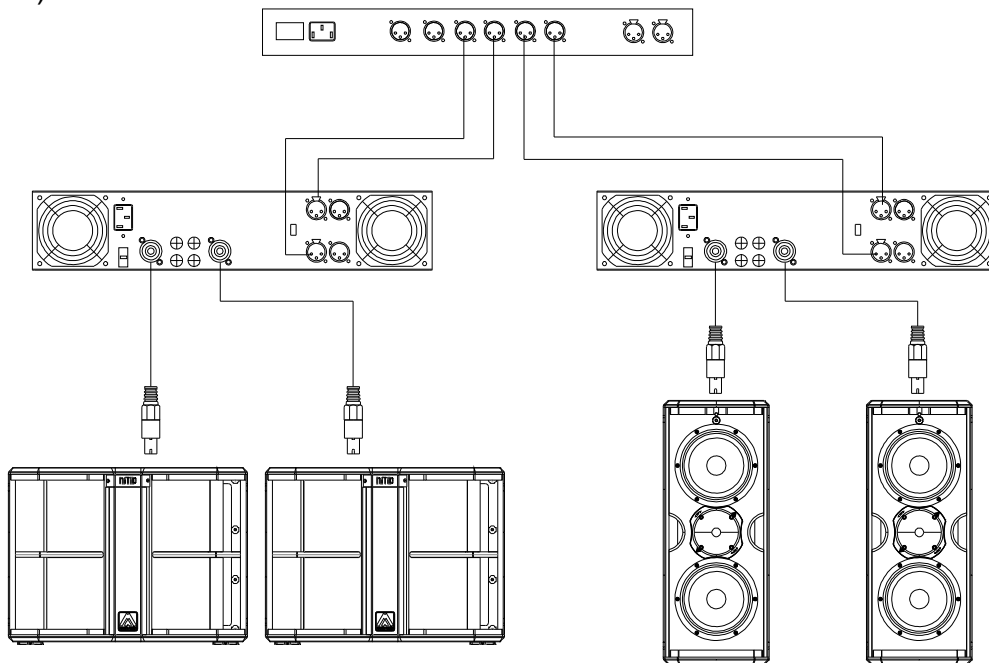

**Fig. 6.** Bi-amplified with subwoofer configuration (option 2)



In order to allow a bridge connection between cabinets, each one of them has been provided with two Speakon connectors that allow the Input / Output function indistinctly. Terminal Pins +1/-1 must be always used, disregarding the +2/-2 which are not internally connected.

### 3. MOUNTING AND PLACEMENT

Flying an S26P system is easy, fast and secure. To perform any operations related to flying the system, read the present document, and act on the warnings and advice given.

Only experienced installers with adequate knowledge of the system and local safety regulations should fly speaker cabinets.

It is the user's responsibility to ensure that the systems to be flown and the flying accessories (such as chains, eyebolts, lock pins...) comply with state and local regulations. They should be regularly inspected and replaced if in doubt.

When flying enclosures from ceiling support structures, extreme care should be taken to assure the load bearing capabilities of the structures. **Do not fly systems from unsafe structures.**

All flying accessories that are not supplied by Amate Audio are the user's responsibility. Use at your own risk. **Remember that no risks should be taken concerning public safety.**

#### 3.1. Placement

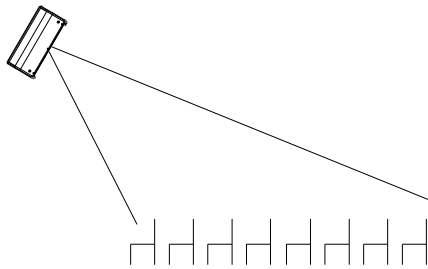

When possible, cabinets should be located in a high position, slightly inclined to the audience. If the loudspeakers are located too low, the listeners at the end of the room will not hear a good sound quality.

**Fig. 7.** Flying placement

#### 3.2. Use with subwoofer or tripod

The S26P is equipped with a 35 mm socket for mounting the speaker on a subwoofer or tripod. Be careful not to use this system on non-flat surfaces as it may become unstable.

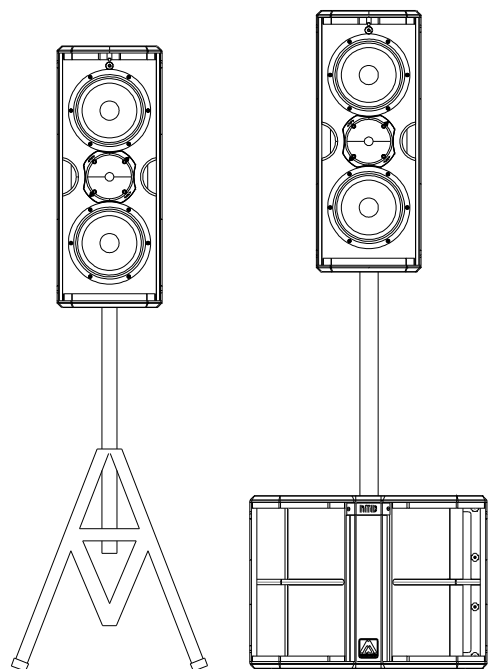
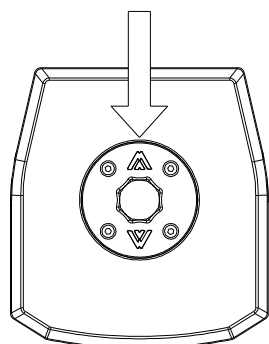

**Fig. 8.** Use with subwoofer and tripod

### 3.3. Rotatable logo

Grille's logo can be rotated.

### 3.4. Flying

Only experienced people should fly speaker cabinets. Extreme care should be taken to assure the load bearing capabilities of the structures where the cabinets will be placed. Hanging hardware (as chains, eyebolts, lock pins...) should be regularly inspected and replaced if in doubt.



**DO NOT SUSPEND  
THE CABINETS FROM  
THE HANDLES**

#### 3.4.1. Vertical flying with HR-LU and HR-LU/GT bar

The HR-LU and the HR-LU/GT are some optional accessories for flying on truss or ceiling (vertical orientation) one unit of S26P. Refer to "HR-LU instructions manual" and "HR-LU/GT instructions manual" for more information.

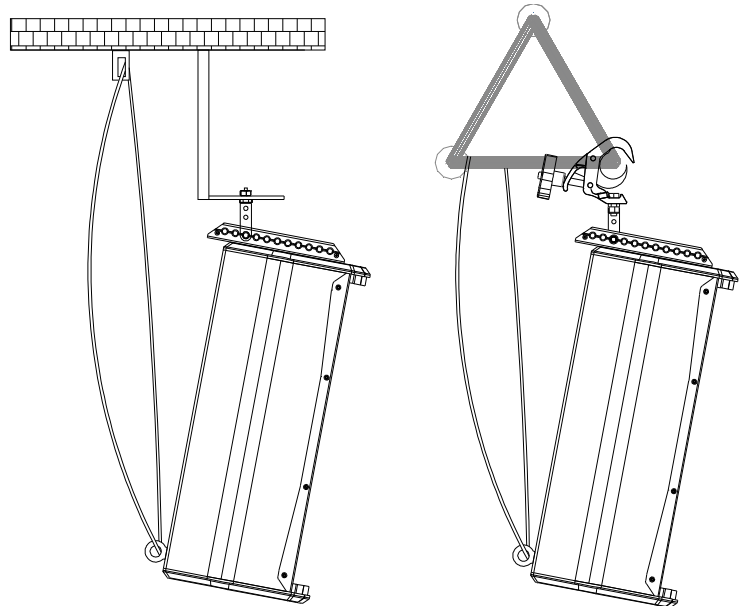

**Fig. 9.** HR-LU and HR-LU/GT flying bar for S26P

#### 3.4.2. Vertical flying with SP-6N

The SP-6N is an optional accessory for mounting on wall (vertical orientation) one unit of S26P. Refer to "SP-6N instructions manual" for more information.

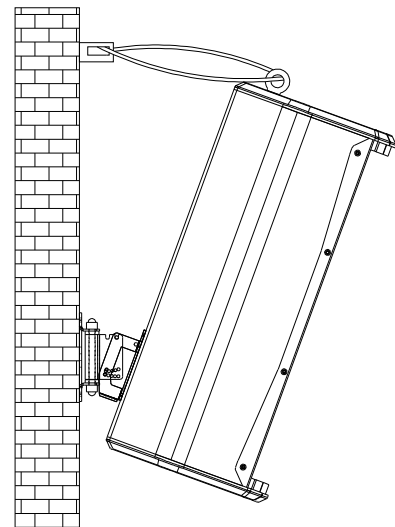

**Fig. 10.** SP-6N bracket for S26P

#### 3.4.3. Vertical flying with SP-WHR

The SP-WHR is an optional accessory for mounting on wall (vertical orientation) one unit of S26P. Refer to "SP-WHR instructions manual" for more information.

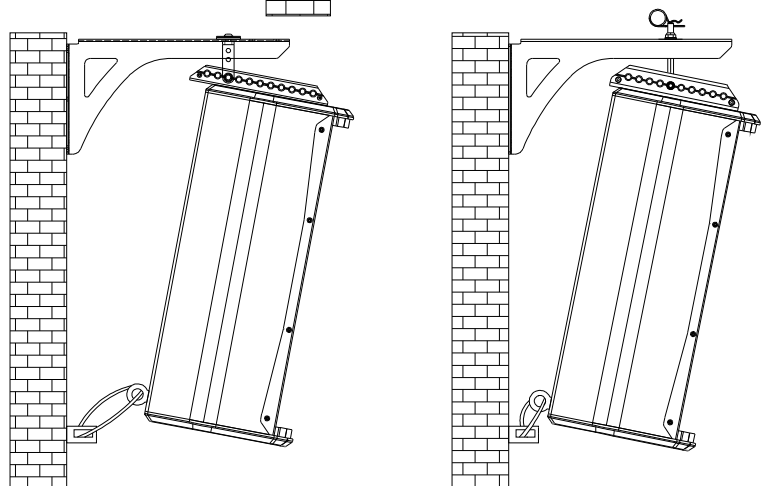

**Fig. 11.** SP-WHR bracket for S26P

### 3.4.4. Flying with ACRM8

The S26P provides several M8 flying points. Their correct use will permit the flying in vertical position.

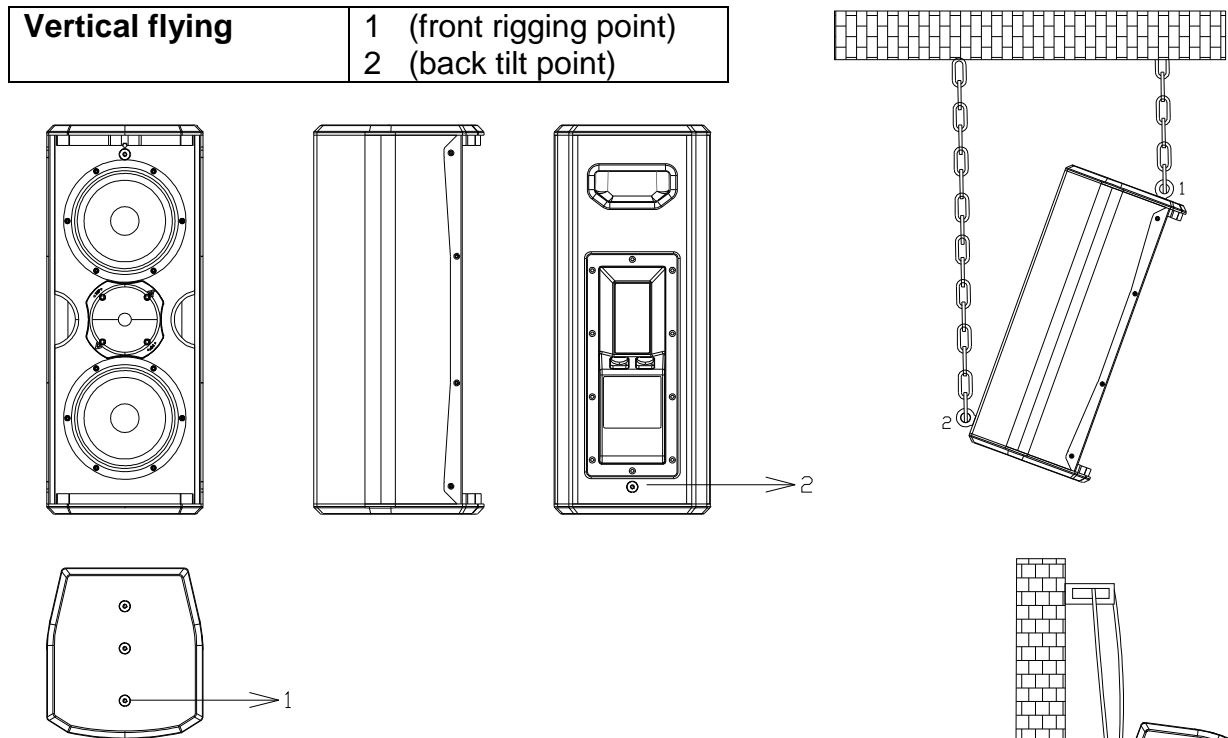

**Fig. 12.** S26P flying with ACRM8

### 3.4.5. Horizontal flying with UB-L

The UB-L is an optional accessory for mounting on wall (horizontal orientation) one unit of S26P. Refer to “UB-L instructions manual” for more information.

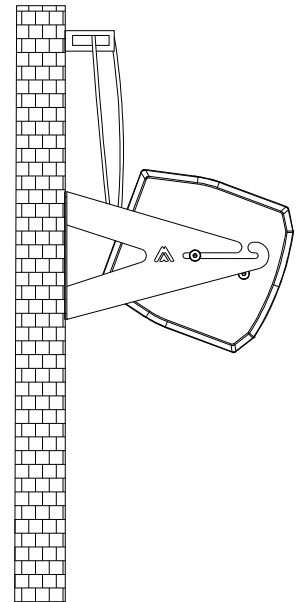

**Fig. 13.** U-BL bracket for S26P

### 3.4.6. Horizontal flying with SP-S26

The SP-S26 is an optional accessory for mounting on wall (horizontal orientation) one unit of S26P. Refer to “SP-S26 instructions manual” for more information.

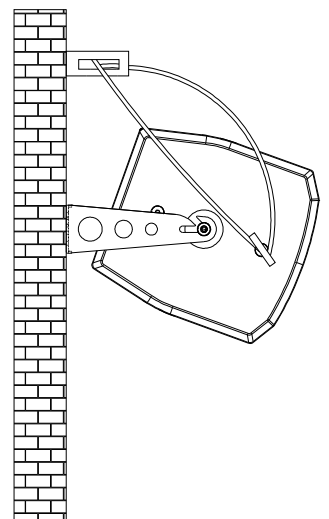
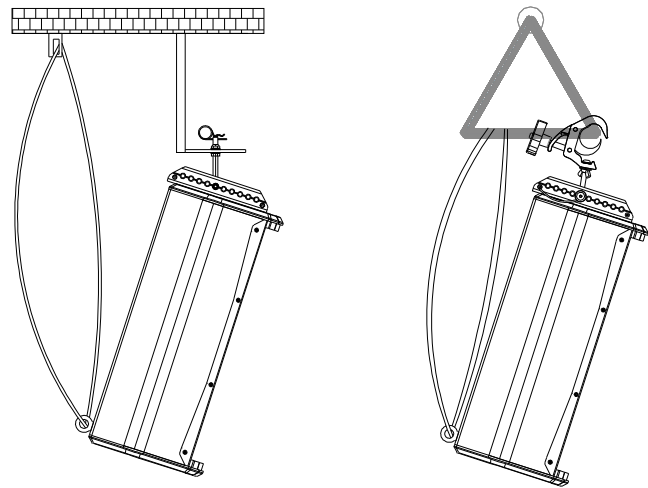

**Fig. 14.** SP-S26 bracket for S26P



**3.4.7. Vertical flying with RB-S bar and RB-S/GT**

For the S26P, use the RB-S or RB-S/GT flying bar for vertical flying. Refer to “RB-S instructions manual” and “RB-S/GT instructions manual” for more information.



**Fig. 15.** RB-S and RB-S/GT flying bar for S26P

**4. TECHNICAL FEATURES**

|  | <b>S26P</b>  |
|--|--|
| <b>Impedance</b>                             |  |
| Nominal                                      | 8 Ω or 16 Ω  |
| <b>Power</b>                                 |  |
| R.m.s  | 200 W  |
| Program                                      | 400 W  |
| Connectors                                   | 1 x Speakon NL4MP input<br>1 x Speakon NL4MP link  |
| <b>Audio Performance</b>                     |  |
| Frequency response (-10 dB usable bandwidth) | 62 Hz – 20k Hz   |
| SPL (1W / 1m)                                | 95 dB  |
| Nominal directivity (-6dB)                   | 70° x 70°  |
| <b>Components</b>                            |  |
| LF   | 2 x 6” neodymium woofers (1.5” voice coil) with carbon fibre cone                                      |
| HF   | 1 x 1” PEN diaphragm neodymium compression driver  |
| <b>Cabinet</b>                               |  |
| Type   | Bass-reflex  |
| Height                                       | 572 mm   |
| Width  | 230 mm   |
| Depth  | 250 mm   |
| Weight (net)                                 | 9.3 Kg   |
| Material                                     | Multilayer birch plywood   |
| Finish                                       | Hi-resistance black Polyurea coating. 1.5mm powder coated steel front grille with black acoustic mesh. |

**Note:** Specifications subjected to change without prior notice.



*Great sound  
from Barcelona  
since 1972*

---

The **NITID** loudspeaker systems have been designed,  
engineered and manufactured in Barcelona – SPAIN  
by

---

**Amate Audio S.L.**

Perpinyà, 25 · Polígon Industrial Nord · 08226 Terrassa  
T. +34 93 735 65 65 – F. +34 93 735 60 48 –  
info@amateaudio.com

R&D and FACTORY:  
Violinista Vellsolà, 18 · 08222 Terrassa  
T. +34 93 736 23 90 – F. +34 93 786 47 00

**Barcelona – SPAIN**

---

[www.amateaudio.com](http://www.amateaudio.com)