

S6L

6" TWO-WAY ACTIVE
FULL-RANGE SPEAKER SYSTEM

NÍTID-S



LIGHT
NEODYMIUM
COMPONENTS



CARBON FIBER
CONE



REAR PANEL
TOUCHSCREEN GUI
OPERATION



INTEGRATED POWER &
CONTROL WITH MULTIPLE
PRESETS



HIGH RESISTANCE
POLYUREA®
FINISH



EASY RIGGING &
INSTALLATION
ACCESSORIES

The most compact active system in the NÍTID series. The 6" single woofer and 1" diaphragm compression driver configuration is housed in an enclosure of minimal dimensions, enabling its application in all kinds of installations that demand the highest sound quality from a loudspeaker system with the most discreet possible form factor.

KEY FEATURES

TRANSDUCER TECHNOLOGY

Two-way full range active speaker system comprising a direct radiating 1.5-inch voice coil, neodymium magnet 6" loudspeaker and a 1-inch voice coil diameter, PEN diaphragm neodymium magnet compression driver loaded to a 70° x 70° dispersion horn.

AMPLIFICATION

Onboard 250 W 3rd generation Class D bi-amplification.

Universal switch mode power supply (SMPS) with Power Factor Correction (PFC), allowing constant power delivery from 85 to 265 VAC input and high efficiency (>90%), with extremely compact lightweight form factor.

Automatic EcoMode low power consumption mode when no signal input present.

Connectors mounted on an inclined, recessed moulded connector plate for improved security and environmental protection.

Double PowerCon® connectors (input & link).

ADVANCED DSP SYSTEM CONTROL

Onboard 64-bit precision DSP loudspeaker system control manages amplifier gain and cross-over settings, peak and thermal limiters and mutes. Includes adjustable 294 ms / 100 m delay line for extensive alignment delay and 5-band fully configurable parametric EQ.

High order FIR filtering ensures fully phase coherent PEQ adjustment and absolute phase alignment of common cabinet coupling.

Extensive R&D'd factory presets provide instantaneous system configuration for common applications, including point-source PA, speech and subwoofer coupling.

ALC (Adaptive Loudness Compensation) improves the listening experience when the system is used at low volume levels.

Operation and monitoring of system parameters, presets and user-adjustments is via Amate Audio's unique rear-panel 3.5" TFT colour touchscreen GUI. The front-panel Nítid backlit logo can be switched on or off, or set to indicate system limiting.

DESIGN & ACCESSORIES

Exclusive 1.5mm black mesh speaker grille with optimum perforation gradient and attractive appearance.

Multilayer birch plywood cabinet with Polyurea® coating, providing maximum robustness and strength for touring events production, venue installation and other highly demanding applications.

M8 rigging points for easy flying.

S6L

6" TWO-WAY ACTIVE
FULL-RANGE SPEAKER SYSTEM

NiTiD-S



TECHNICAL FEATURES

Amplifier (program)	200 W (LF) + 50 W (HF) Class D Bi-amplified
Input Sensitivity	8 dBu – 1.94 V
Input Impedance	50 kΩ Balanced
Mains	Universal Switch Mode Power Supply 85-265 V/ 45-65 Hz
Average current draw	0.5 A (Heavy duty musical program)
SPL(1m)	115 dB musical program, 118 dB peak
Built-in DSP	64-bit processing unit. Includes factory presets
AD/DA converters	24 bit – 48 kHz
Standby mode consumption	3.7 W @230VAC
Adjustable delay line	294 ms / 100 m
Crossover frequency	2k5 Hz
Frequency response (-10dB)	62 Hz – 20 kHz
Components	<p>LF-MF 6" neodymium woofer with carbon fiber cone (1.5" voice coil)</p> <p>HF 1" PEN diaphragm neodymium magnet compression driver</p>
Directivity (-6dB)	70° x 70°
Directivity factor (Q)	12.6
Directivity Index (DI)	11 dB
Weight	7.2 Kg
Dimensions (HxWxD)	400 x 230 x 250 mm
Finish	Multilayer baltic birch plywood with high resistant black Polyurea® coating
Grille	1.5 mm powder coated steel with black acoustic mesh
Rigging	M8 points
Connectors	1x XLR input / 1x XLR link / 1x AC PowerCon® input / 1x AC PowerCon® link
Available colors	Black and white

TOUCHSCREEN CONTROL



Amate Audio's latest generation DSP System management is integrated with 3rd generation Class D amplification. Colour touchscreen operation and monitoring of DSP System includes access to powerful presets - engineered by Amate Audio R&D team – that instantly configure your NiTiD loudspeaker for the majority of common application environments within seconds, prior to rigging or installation.



TOP VIEW



BOTTOM VIEW



SIDE VIEW



FRONT VIEW



REAR VIEW

S6L

6" TWO-WAY ACTIVE
FULL-RANGE SPEAKER SYSTEM

NITID-S



FREQUENCY RESPONSE 1w/1m (FLAT PRESET)

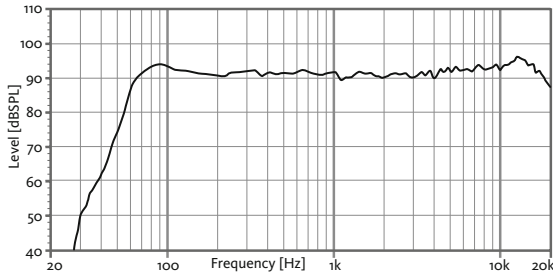

HORIZONTAL COVERAGE

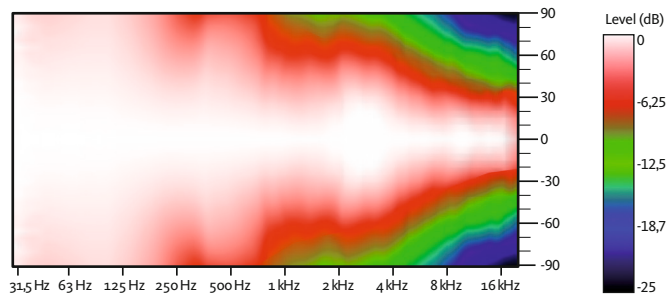

DIRECTIVITY INDEX (DI)

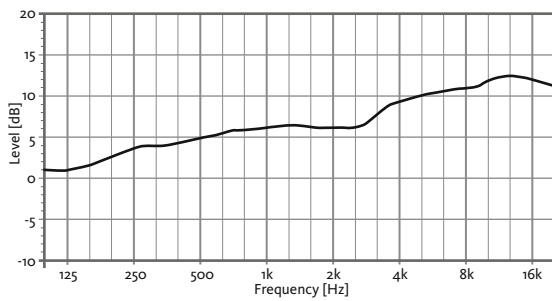

VERTICAL COVERAGE

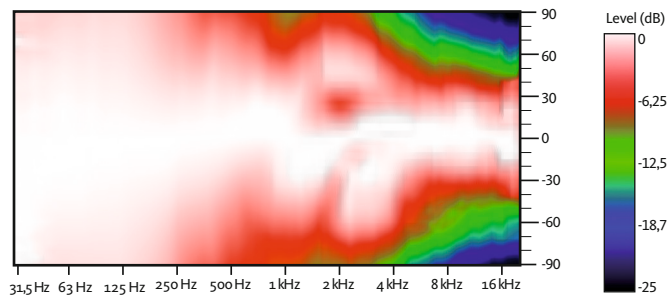

HORIZONTAL & VERTICAL BEAMWIDTH (-6dB point)

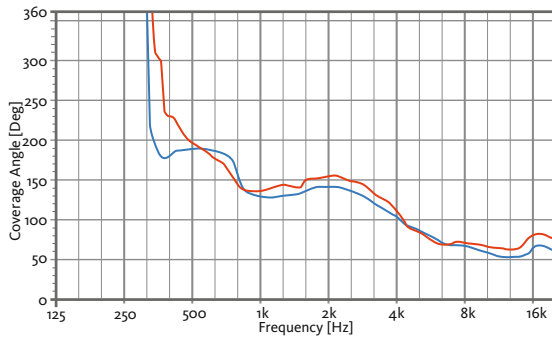

HORIZONTAL VERTICAL

CAD DRAWING SCHEME

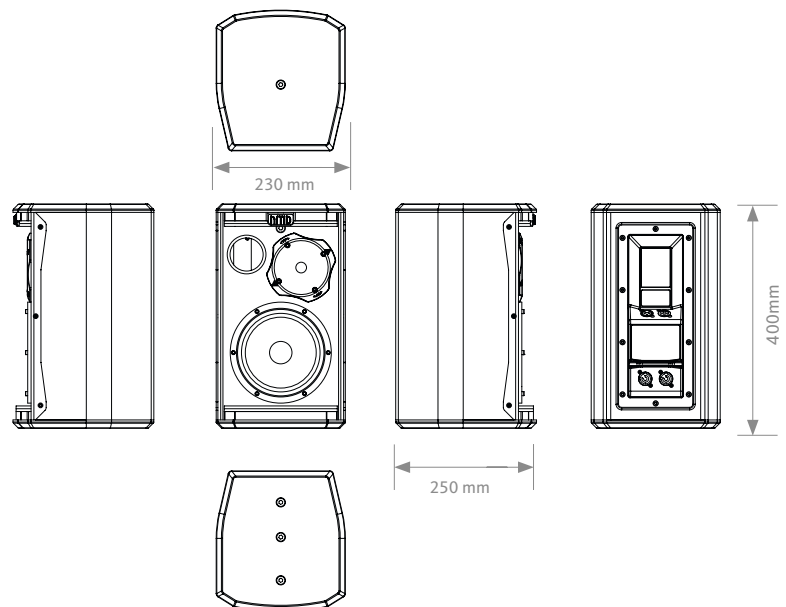

BUILT-IN PRESETS

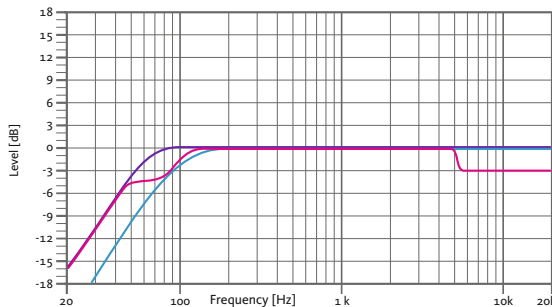

FLAT
Flat response
SPEECH
Vocal use

HPF90
HPF 90 Hz

S6L

6" TWO-WAY ACTIVE
FULL-RANGE SPEAKER SYSTEM

Nítid-S



ACCESSORIES

FLYING BAR
HR-LU



FLYING BAR WITH HOOK
HR-LU/GT



WALL MOUNT BRACKET
SP-6N



WALL-MOUNT BRACKET
SP-WHR



SAFETY SLING
SC-15



DISCOVER NÍTID

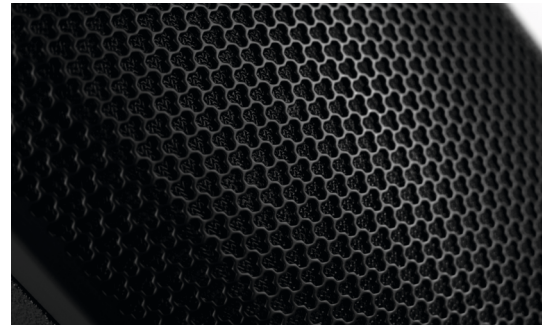

UNIQUE DESIGN

New S-series models build on the success, innovation and best-in-class performance of the original Nítid designs with improved features including a recessed moulded connector plate, more highly stylised form factor and improved robustness of the world's most acoustically transparent pro-audio speaker grille.



THE PERFECT BALANCE

An ongoing programme of research and development ensures that Nítid series loudspeakers continue to achieve the highest levels of output and performance from the most compact sized designs, in an unrivalled synthesis of engineering and aesthetic form.

VERTICAL TRUSS-MOUNT
HR-LU/GT + SC-15

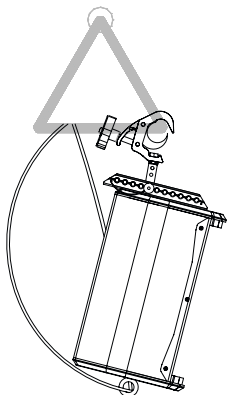

VERTICAL WALL-MOUNT
SP-6N + SC-15

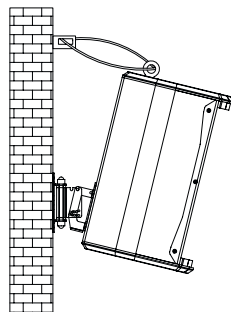

VERTICAL COLUMN-MOUNT
HR-LU + SC-15

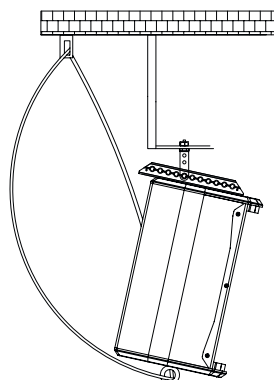

VERTICAL WALL-MOUNT
SP-WHR + SC-15

